

Fiji LX

H 125
P 63 • 78
L 4 • 6 • 7 • 9 • 120 • 140

Gelato

	TN Chiller	TB Freezer	TB/TN Dual Temp
RS-Static			
RV-Ventilated		•	
TCS-Heated			
CH-Chocolate			

Installation
Plug-in

Temperature
-16/-14 °C

Refrigerant
R404A

Refrigeration
Ventilated

Compressor
Hermetic

Defrost
Hot gas

Climate class
7

Upper class
Tempered

Front glass
Tempered

Side glass
Tempered

Rear closing system
Tilting panel

Work top
White prepainted sheet

Lighting
Led 5700 K

Equipment handling
Swivel casters with brake

Installazione
Plug-in

Temperatura
-16/-14 °C

Refrigerante
R404A

Refrigerazione
Ventilata

Compressore
Ermetico

Sbrinamento
Gas caldo

Classe climatica
7

Vetro superiore
Temperato

Vetro frontale
Temperato

Vetri laterali
Temperato

Chiusura posteriore
Ribaltina basculante

Piano di servizio
Lamiera preverniciata bianca

Illuminazione
Led 5700 K

Movimentazione
Ruote pivotanti con freno

Internal color
Colore interno

White

Front color
Colore frontale

White

Sides color
Colore fianchi

White



Fiji LX

	4	6	7	9
External dimensions (LxDxH) Dimensioni esterne (LxPxH)	824x630x1247 mm	1214x630x1247 mm	1354x630x1247 mm	1659x630x1247 mm
Capacity (gross/net) Capacità (lorda/netta)	218 / 119 Lt	339 / 185 Lt	383 / 209 Lt	478 / 261 Lt
Net weight Peso netto	67 kg	99 kg	110 kg	135 kg
Refrigeration Refrigerazione	Ventilated Ventilata			
Refrigerant Refrigerante	R290			
Climate class Classe climatica	7			
Operating conditions Condizioni ambientali	35 °C / 75 %RH			
Product temperature Temperatura prodotto	-16/-14 °C			
Compressor (q.ty - type) Compressore (q.tà - tipologia)	1 - Hermetic 1 - Ermetico			
Defrost Sbrinamento	Hot gas Gas caldo			
Power supply Alimentazione	230 V / 1 Ph / 50 Hz			
Electrical input (nominal) Assorbimento elettrico (regime)	555 W / 2,5 A	900 W / 4,1 A	980 W / 4,5 A	
Electrical input (defrost) Assorbimento elettrico (sbrinamento)	1425 W / 6,5 A	1860 W / 7,5 A	1960 W / 8,3 A	

Technical sheet about models whit condensing unit included with air cooled
Dati tecnici riferiti a modelli con unità a bordo con condensazione ad aria

Setup

Allestimento

5 Lt * 360 x 165 x 120 h		4 + (4)	6 + (6)	7 + (7)	9 + (9)
4,75 Lt 260 x 157 x 170 h		4	6	7	9

* Piled up double row Doppia fila di riserva

Item

Accessorio

White cone holder Portaconi completo bianco					•
Scoop washer with stainless steel container Lavaporzionatore vaschetta inox					•

	120	140
1214x785x1247 mm	1214x785x1247 mm	1354x785x1247 mm
459 / 243 Lt	518 / 274 Lt	
110 kg	135 kg	
Ventilated Ventilata		
R290		
7		
35 °C / 75 %RH		
-16/-14 °C		
1 - Hermetic 1 - Ermetico		
Hot gas Gas caldo		
230 V / 1 Ph / 50 Hz		
950 W / 4,3 A	1000 W / 4,5 A	
2000 W / 8 A	2050 W / 8,4 A	

9 + (9)	10 + (10)
12	14

	•
	•



Display - piled up double row - 5 Lt
Vasca espositiva - doppia fila di riserva - 5 Lt

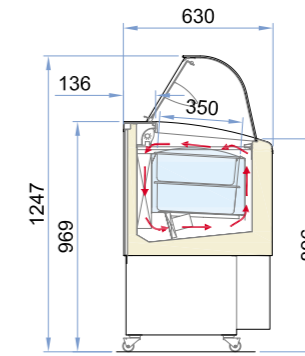

4 - 6 - 7 - 9

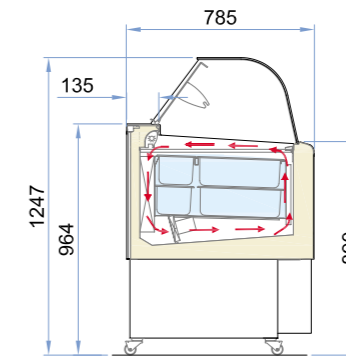

120 - 140